



**DOW™ Ultrafiltration Modules**  
**Model SFP-2860 and SFD-2860**

**Features**

The DOW™ Ultrafiltration (UF) modules are made from high strength, hollow fiber membranes that have excellent features and benefits:

- 0.03 µm nominal pore diameter for removal of bacteria, viruses, and particulates including colloids to protect downstream processes such as RO
- PVDF polymeric hollow fibers for high strength and chemical resistance allows long membrane life
- Hydrophilic PVDF fibers for easy cleaning and wettability that help maintain long term performance
- Outside In flow configuration for high tolerance to feed solids that help reduce the need for pretreatment processes
- U-PVC housing, helping to eliminate the need for costly pressure vessels

This module is an ideal choice for systems with capacities greater than 50 m3/hr (220 gpm). The larger, 8 inch diameter module offers the highest effective membrane area of the DOW UF modules, which contributes to a more economical membrane system design. The shorter, 60 inch length module offers higher efficiencies over a wider range of feed water conditions compared to longer length modules.

DOW™ Ultrafiltration Modules can be used for a wide variety of treatment applications such as surface water, seawater, industrial wastewaters, and secondary effluent wastewater.



**Product Specifications**

Model	Type	Part #	Membrane area		Module volume		Weight (empty/ water filled)	
			m <sup>2</sup>	ft <sup>2</sup>	Liters	Gallons	Kg	lbs
SFP-2860	Pretreatment	280933	51	549	35	9.3	48/83	106/183
SFD-2860	NSF/ANSI 61 Drinking water	324168	51	549	35	9.3	48/83	106/183

**Figure 1:** SFP and SFD 2860 (8-inch diameter)

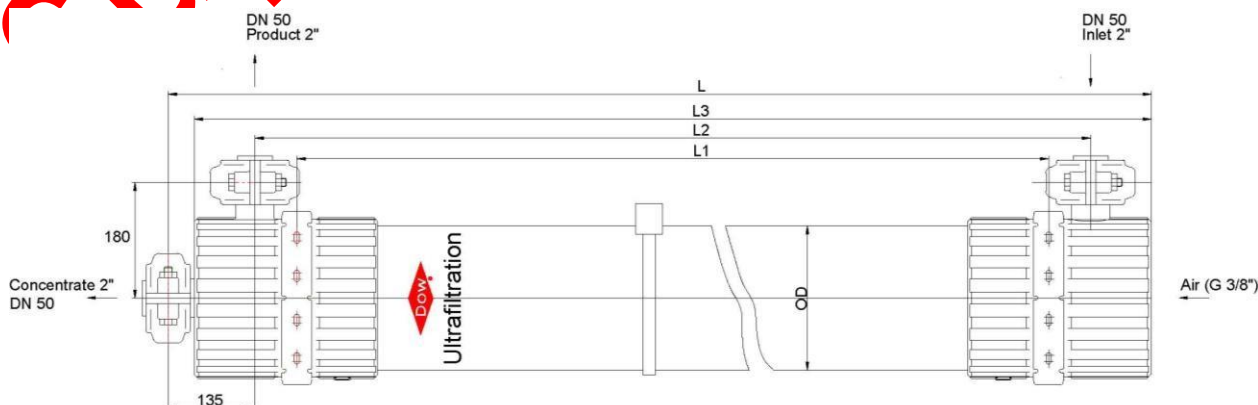

**Figure 2**

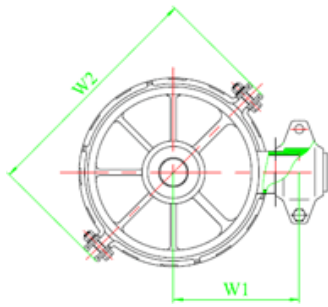

Properties	Length				Diameter	Width	
	Units	L	L1	L2		L3	D
SI (mm)	1860	1500	1630	1820	225	180	342
US (inch)	73.2	59.1	64.2	71.7	8.9	7.1	13.5

**Operating Parameters**

	SI units	US units
Filtrate Flux @ 25°C	40-120 l/m <sup>2</sup> /hr	24-70 gfd
Flow range	2.0 – 6.1 m <sup>3</sup> /hr	9.2 – 26.7 gpm
Temperature	1-40°C	34-104°F
Max. inlet module pressure (@ 20°C)	6.25 bar	93.75 psi
Max. operating TMP	2.1 bar	30 psi
Max operating air scour flow	12 nm <sup>3</sup> /hr	7.1 scfm
Max backwash pressure	2.5 bar	36 psi
Operating pH	2- 11	
NaOCl (max.)	2,000 mg/L	
TSS (max.)	100 mg/L	
Turbidity (max.)	300 ntu	
Particle size (max.)	300 μ	
Flow configuration	Outside in, dead end flow	
Expected filtrate turbidity	≤0.1 NTU	
Expected filtrate SDI	≤2.5	

**Important information**

Proper start-up of a UF system is essential to prepare the membranes for operating service and to prevent membrane damage. Following the proper start-up sequence also helps ensure that system operating parameters conform to design specifications so that system water quality and productivity goals can be achieved. Before initiating system start-up procedures, membrane pretreatment, installation of the membrane modules, instrument calibration and other system checks should be completed. Please refer to the product technical manual.

**Operation guidelines**

Avoid any abrupt pressure variations during start-up, shutdown, cleaning or other sequences to prevent possible membrane damage. Flush the UF system to remove shipping solution prior to start up. Remove residual air from the system prior to start up. Manually start the equipment. Target a permeate flow of 60% of design during initial operations. Depending on the application, permeate obtained from initial operations should be discarded. Please refer to the product technical manual.



**General information**

If operating limits and guidelines given in this bulletin are not strictly followed, the limited warranty (Form No. 795-00027) will be null and void.

To prevent biological growth during system shutdowns, it is recommended that preservative solution be injected into the membrane modules.

**Regulatory note**

NSF/ANSI 61 certified drinking water modules require specific conditioning procedures prior to producing potable water. Please refer to the product technical manual flushing section for specific procedures. Drinking water modules may be subjected to additional regulatory restrictions in some countries. Please check local regulatory guidelines and application status before use and sale.

For more information about DOW™ resins, call the Dow Water & Process Solutions business:  
North America: 1-800-447-4369  
Latin America: (+55) 11-5188-9222  
Europe: +800-3-694-6367  
Italy: +800-783-825  
South Africa: +0800 99 5078  
Pacific: +8007776 7776  
China: +400 889-0789  
<http://www.dowwaterandprocess.com>

NOTICE: The use of this product does not necessarily guarantee the removal of cysts and pathogens from water. Effective cyst and pathogen reduction is dependent on the complete system design and on the operation and maintenance of the system.

Notice: No freedom from infringement of any patent owned by Dow or others is to be inferred. Because use conditions and applicable laws may differ from one location to another and may change with time. Customer is responsible for determining whether products and the information in this document are appropriate for Customer's use and for ensuring that Customer's workplace and disposal practices are in compliance with applicable laws and other governmental enactments. The product shown in this literature may not be available for sale and/or available in all geographies where Dow is represented. The claims made may not have been approved for use in all countries. Dow assumes no obligation or liability for the information in this document. References to "Dow" or the "Company" mean the Dow legal entity selling the products to Customer unless otherwise expressly noted. NO WARRANTIES ARE GIVEN; ALL IMPLIED WARRANTIES OF MERCHANTABILITY OR FITNESS FOR A PARTICULAR PURPOSE ARE EXPRESSLY EXCLUDED.

